

## Content

+ +	Content .....	1
+	Functional Flowchart .....	2
+	Objective .....	2
+	Scope .....	2
	Definitions .....	3
	Responsibilities .....	3
	OH&S Systems Manager .....	3
	Station / Site Manager .....	3
	OIC and Crane Operator .....	3
	Workers .....	3
	Hazards .....	5
	Risk Assessment .....	5
	Planning and Pre-Work Considerations .....	5
	General Crane and Hoist Issues .....	5
	Specific Crane Considerations .....	5
	Controls .....	6
	Specific Crane and Hoist Use Controls .....	6
	Cranes and Hoists - General Requirements .....	6
	Cranes - Mobile .....	7
	Site Specific Management Of Cranes And Hoists .....	8
	Contractor Management .....	9
	Training and Competency .....	9
	Review .....	9
	Links and References .....	9
	Attachments .....	10

## Functional Flowchart

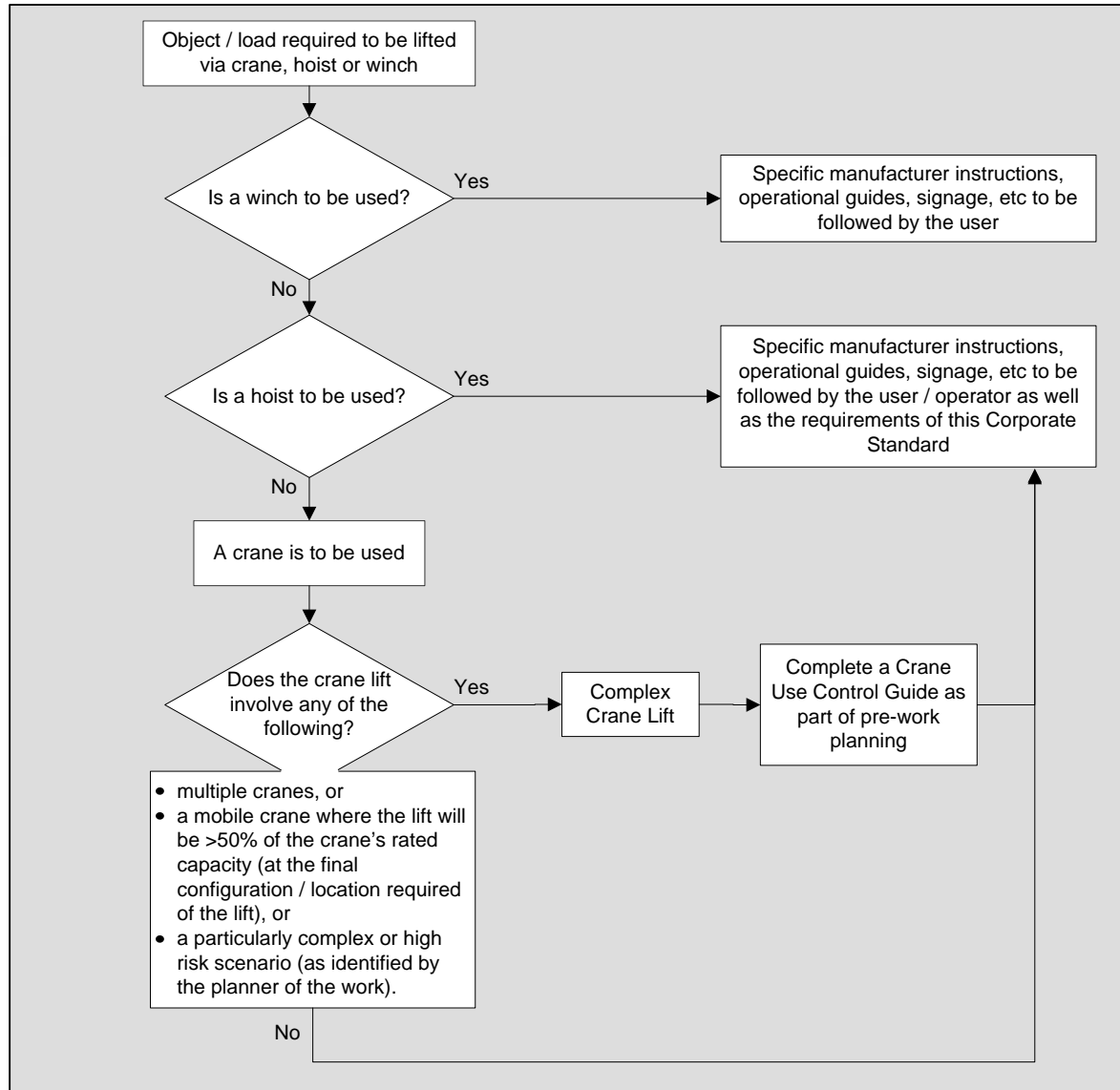

## Objective

To provide a corporate standard that outlines SCL's procedure for managing hazards relating to crane and hoist use and the methods by which safe crane and hoist lifting controls are to be implemented.

## Scope

This corporate standard applies to any work location where the use of a crane or hoist is required within a SCL operated and / or maintained site or any situation in which an SCL employee or SCL controlled contractor is required to undertake specific crane or hoist lifting tasks.

### ++ Definitions

+ **Arduous working condition:** Means items that induce additional stresses on the structure or mechanics of a crane not usually encountered over its working life when used in normal operation. Refer to AS1418.14 – Cranes (including hoists and winches) - Requirements for cranes subject to arduous working conditions and Attachment 1, for examples of typical arduous working conditions.

+ **Competent Person:** A person who has through a combination of training, education and experience, acquired knowledge and skills enabling that person to perform correctly the specified task.

**Crane:** An appliance intended for raising or lowering a load and moving it horizontally, but does not include an industrial lift truck, earthmoving machinery, an amusement structure, a tractor, an industrial robot, a conveyor, a suspended scaffold or a lift. Refer to Attachment 2, for examples of various cranes.

**Dogger:** Means a person who:

- a) uses techniques, including the selection or inspection of lifting gear, to safely sling a load, or
- b) directs a crane or hoist operator in the movement of a load when the load is out of the operator's view.

Note: Such a competent person must possess a Dogger's certificate of competency from one of the various statutory health and safety authorities.

**Hoist:** For the purposes of this document, an appliance intended for raising and lowering a load vertically and without slewing which includes basic chain hoists but does not include complex hoists such as mast climbing work platforms, personnel and materials hoists, scaffolding hoists or serial hoists, or lifts or building maintenance equipment.

**Lift Supervisor:** A competent person who supervises SCL crane activities involving multiple crane lifting operations or complex and high risk single crane lifting operations on site.

Note: Such a competent person must possess an Intermediate Rigger's certificate of competency (minimum) from one of the various statutory health and safety authorities.

**Rated capacity:** The maximum gross load which may be applied to the crane or hoist or lifting attachment while in a particular working configuration and under a particular condition of use. Previously known or referred to as Safe Working Load (SWL) or Working Load Limit (WLL).

**Rigging work:** Means using mechanical load shifting equipment and associated gear:

- a) to move, place or secure a load, or
- b) to set up or dismantle a crane or hoist.

Note: Such a person undertaking rigging work must possess a Rigger's certificate of competency (Basic, Intermediate or Advanced as applicable) from one of the various statutory health and safety authorities. See table below for basic, intermediate and advanced rigger details.

Rigger Type	Definition
Basic	Means a person who performs – <ul style="list-style-type: none"> <li>a) the work of a dogger, and</li> <li>b) rigging work associated with –               <ul style="list-style-type: none"> <li>i) the movement of plant or equipment, or</li> <li>ii) the placement of precast concrete, or</li> <li>iii) hoists other than hoists with jibs and self-climbing hoists, or</li> <li>iv) steel erection, or</li> <li>v) safety nets and static lines, or</li> </ul> </li> </ul>

# Corporate Standard

## Crane and Hoist Use PTW

HB# 537642

Amd Date 04/01/08

	vi) mast climbers, or vii) perimeter safety screens and shutters, or viii) cantilevered crane loading platforms.
Intermediate	Means a person who performs – a) the work of a basic rigger, and b) rigging work associated with – i) hoists, or ii) cranes, conveyors, dredges and excavators, or iii) tilt slabs, or iv) demolition work, or v) dual lifts.
Advanced	Means a person who performs – a) the work of an intermediate rigger, and b) rigging work associated with – i) gin poles and shearlegs, or ii) flying foxes and cable ways, or iii) guyed derricks and structures, or iv) suspended scaffolds and fabricated hung scaffolds.

**Slinging techniques:** The exercising of judgement in relation to the suitability and condition of lifting gear and the method of slinging, by considering the nature of the load, its mass and its centre of gravity.

**Winch:** A device operated manually or by power and comprised of a rope and winding drum or a load chain wheel for the purpose of providing a haulage or pulling force.

Note: The scope of this standard does not focus specifically on winches. As a minimum however, specific manufacturer instructions, operational guides, signs, etc are to be followed when using winches.

**Workbox:** A personnel-carrying device, designed to be suspended from a crane, which provides a working area for persons elevated by and working from the box. Workboxes must be designed in compliance with AS 1418.17.

## Responsibilities

### OH&S Systems Manager

To maintain the currency and accuracy of the Crane and Hoist Use Corporate Standard reflective of legislative and corporate change.

### Station / Site Manager

To monitor the implementation of the Crane and Hoist Use Corporate Standard and allocate responsibilities and resources to ensure site-specific practices/procedures are developed to satisfy the Corporate Standard.

### OIC and Crane Operator

To ensure safe assessment, control implementation, contractor management and overall safe crane use in accordance with this Corporate Standard and any site-specific file information.

### Workers

To comply at all times with the requirements specified within this Corporate Standard and any site-specific procedures.

## ++ Hazards

- + The planning of crane and hoist operations is vital in order to maintain safe operation of all equipment and to ensure that specific lifting tasks are carried out without incident. Despite the large range of crane and hoist types and their varied uses, a safe system must be implemented to control risks to health, safety and the environment arising from items such as, but not limited to:
  - + the overloading of a crane / hoist or lifting attachment;
  - + incorrect lifting configurations or methods;
  - inadequate slinging or securing of loads, including the failure to check sling integrity,
  - unsafe erection and dismantling procedures;
  - unstable ground surfaces or supporting structure features; and
  - nearby overhead power lines, plant or structures.

## Risk Assessment

### Planning and Pre-Work Considerations

#### *General Crane and Hoist Issues*

Prior to undertaking lifting tasks involving a crane/hoist, personnel are to consider the following types of issues to ensure that safe crane/hoist practices are achieved:

- that the rated capacity of the crane/hoist is able to safely accommodate the mass of the load required to be lifted;
- whether specific items of lifting equipment may be required;
- that safe slinging techniques are used not only to safely secure the load but to ensure that excessive swinging of the load during vertical lifting will not occur;
- that safe clearance distances are available in and around existing plant and structures to enable safe hoisting and slewing of the load;
- that measures have been considered for the setting down of the load such that lifting equipment can be easily retrieved and so that the load does not overturn or fall.

#### *Specific Crane Considerations*

Further to the items mentioned previously, additional issues need to be considered for the use of mobile cranes. These include:

- the ability to safely access the location at which the crane is required to be sited;
- clearance distances from overhead structures, plant and overhead lines and distances around the crane during movement and slewing operations;
- ground conditions and slope constraints for the siting of the crane;
- floor or structure capacities and limitations for the siting of the crane; and
- weather conditions that may affect the lifting tasks.

A Crane Use Control Guide is to be completed for lifting tasks outlined in the following table.

Crane Types	Lifting Description
All cranes	<ul style="list-style-type: none"> <li>▪ Lifts involving multiple cranes</li> <li>▪ Lifts assessed as being particularly complex or high risk by OICs or others planning the work due to:               <ul style="list-style-type: none"> <li>– the vicinity to site plant or assets;</li> <li>– the complexity of the lifting arrangement or configuration;</li> <li>– the nature of the load being lifted; or</li> <li>– unfavourable weather or environmental conditions.</li> </ul> </li> </ul>
Mobile cranes	<ul style="list-style-type: none"> <li>▪ Lifts &gt;50% of the crane's rated capacity (at the final configuration / location required of the lift).</li> </ul>

- + + Prior to hiring a mobile crane to undertake specific lifting tasks at a SCL site, a competent person who has an understanding of the general lifting tasks required is to provide relevant information to the crane supply company. This may include:
  - characteristics such as mass, size, shape, etc of the loads to be lifted, and
  - details of any arduous lifting conditions that cannot be avoided.
- + Where possible, a mobile crane that can easily accommodate the required loads to be lifted is to be selected.
- + That is, a crane that is not required to perform lifts that exceed 50% of its rated capacity for the particular lifts and configurations required.

Prior to the commencement of crane activities, the crane is to be given a visual inspection and functional test by a competent person (i.e. operator). The visual and functional test is to include the following as a minimum:

- operating and emergency controls;
- brakes;
- safety switches and interlocks;
- structure; and
- wire ropes to ensure they are not damaged, on the drum and correctly reeved on the sheave.

Note: Typically, this would occur at the commencement of the shift / working day.

## Controls

### Specific Crane and Hoist Use Controls

#### *Cranes and Hoists - General Requirements*

Only lifting equipment items that have been inspected and used in accordance with [HB#560726 Corporate Standard Lifting Equipment](#) are to be attached to cranes and hoists for lifting purposes.

Loads are to be lifted in a way that is consistent with the design and intended use of the crane or hoist and its associated lifting equipment.

Under no circumstances are loads to be lifted above or over personnel who are working in the vicinity of the crane or hoist. Similarly, personnel are not permitted to access or work beneath loads that are suspended.

Acceleration and braking motions during travelling are to be applied in a controlled and gentle manner to minimise load swing and shock loading to equipment. This includes:

- overall movement of a bridge or gantry type crane;
- movement of a mobile crane that is vehicle based, during lifting; and
- slewing of mobile cranes during lifting.

A dogger is to be used to direct a crane operator in the movement of a load when the load is out of the crane operator's view. Where possible doggers are to be positioned such that they are:  
clearly visible to the crane operator; and  
not located between a suspended load and the crane.

Except for specific maintenance, commissioning, erection or dismantling purposes, only those personnel correctly accommodated in the cabin or on the working platform are to be permitted on the crane when it is operating.

No personnel are to enter a crane's operating zone (area in and around the crane) during normal operations unless the crane operator is made aware of their presence. This can be achieved via establishing voice or visual contact with the operator.

- + + A person may only be suspended from a crane hook when accommodated within a workbox designed for the purpose in accordance with AS 1418.17 – Cranes (including hoists and winches) – Design and construction of workboxes.

The use of a workbox, with persons attached within via fall arrest harnesses and lanyards, is to be limited to those situations where it is necessary to elevate personnel to carry out work where it is not possible to use scaffolding or equipment such as elevating work platforms designed specifically to lift personnel, or where these means are unsafe or not practicable to implement.

A crane operator is not to leave the cabin / controls of a crane while a load is suspended. Furthermore, a crane or hoist is not to be left unattended unless the following actions, where applicable, have been taken:

- all loads have been removed from the hook;
- the hook has been raised to a position where it is safely clear of other operations, hooked back or otherwise appropriately secured;
- all powered motions have been disabled; and
- where applicable, access to the cabin / controls has been securely restricted.

All cranes are to be kept clean and maintained such that:

- loose objects, tools, materials, etc are not left on any area of the crane from which they could fall; and
- grease and oil spills, debris and other materials that could cause a slip or trip hazard are removed from the crane and associated walkways, stairways, platforms and ladders.

#### *Cranes - Mobile*

Crane operators are to observe safe approach distances / exclusion zones for overhead powerlines in accordance with [HB#560790 Corporate Standard Electrical Safety](#). This may include ensuring that safety observer zones are complied with.

Where applicable, tag lines are to be used to prevent pendulum motion of a load.

Loads are to be carried as near to the supporting surface as is practicable.

In relation to vehicle mobile cranes that are used to undertake pick and carry type tasks:

- cranes are not to be operated on a slope angle that exceeds manufacturer specifications;
- direction of travel is to be up or down slopes without traversing in any way;
- loads are to be carried on the uphill side of the crane, irrespective of the direction of travel up or down the slope;
- specific planning and checks are to be undertaken to ensure that ground and slab conditions are adequate and that obstacles have been controlled; and
- they are not to travel while people are suspended within a workbox.

Specific precautions are to be taken during crane operation, load placement and when selecting lifting equipment to ensure that the crane's boom is not subjected to side loading.

In relation to mobile crane set-up, the following controls are to be implemented to ensure safe lifting activities can be undertaken:

- all outrigger jacks are to be fitted correctly with foot plates and adjusted in accordance with the operating instructions, to provide a base for the crane within the manufacturer's tolerances;
- outriggers are to be fully extended (wherever possible) or positioned in accordance with manufacturer instructions relative to the type of load and lift required;
- mats, steel plates, timber sleepers, a concrete raft or similar aids are to be used to distribute the operational loads under the support points of the crane so that the bearing capacity of the supporting surface is not exceeded.

# Corporate Standard

## Crane and Hoist Use PTW

HB# 537642

Amd Date 04/01/08

- + + If a crane is to be positioned / operated in a trafficable area, appropriate barricades and signage are to be erected to prevent pedestrian and / or vehicular traffic from entering the operating zone of the crane. Refer also to [HB#659518 Corporate Standard Barricading and Restricted Access](#) .

If a crane or load contacts aerial conductors (eg overhead powerlines), that are energised or that are without a documented isolation having been undertaken to prove that they are de-energised, the relevant electrical authority is to be immediately notified, and until assistance is received, a competent person is to remain in a prominent position to warn personnel of the electrical hazard. Immediate actions are to be taken to de-energise the conductors.

If a crane or load contacts aerial conductors the crane operator is to act as follows:

- remain inside the cabin or on the crane,
- warn all other personnel to keep away from the crane and not to touch any part of the crane, rope or load;
- without anyone approaching the crane, operate the crane in such a manner to break contact, where possible;
- when unable to move or disentangle the crane from the aerial conductors, remain inside the cabin or on the crane and take no further action until it is confirmed that conditions are safe and the conductors are de-energised;
- when it is necessary to leave the cabin or crane because of fire or some other reason to avoid electrocution:
  - jump clear, as far away from the crane as possible;
  - avoid touching the crane and the ground at the same time; and
  - when moving away from the crane, shuffle or hop slowly across the affected area to avoid a simultaneous contact with areas of high potential difference.

### Site Specific Management Of Cranes And Hoists

Inspections, preventative maintenance and repairs are to be carried out on all SCL owned cranes and hoists in accordance with the plant manufacturer's requirements.

Regular inspections, inclusive of pre-use inspections, are to be carried out by crane operators, whereas specific maintenance and repair tasks are to be carried out by a representative of the manufacturer, supplier or an equivalent reputable servicing company.

Where specific maintenance and repair tasks are undertaken, inspection and test certificates and records are to be obtained from the manufacturer, supplier or equivalent reputable servicing company. These records are to be maintained for the life of the plant item.

Service logbooks that contain details of daily inspections and a summary of repairs and maintenance are to be kept within each SCL owned crane and are to be maintained by the crane operator(s) or another designated competent person. Details of crane maintenance, servicing and repairs are to be maintained in an easily accessible file / register on site.

The inspection, testing and maintenance of all SCL owned lifting equipment is to be undertaken in accordance with [HB#560726 Corporate Standard Lifting Equipment](#).

Mobile cranes with a rated capacity / SWL greater than 10t, are to be inspected by a competent person before registration on 31st January each year. Mobile cranes are also to have a major inspection undertaken every ten (10) years by a suitably qualified engineer.

Note: A competent person is someone who has a sound knowledge of relevant Australian standards, codes of practice and legislation. They must also have skills in risk management processes and design procedures for the erection, operation, maintenance, repair, alteration and dismantling of cranes.

### Contractor Management

SCL is to ensure that all subcontractors who are contracted to undertake crane operations on site hold the relevant certificates of competency / licences (ie crane operator, rigger, dogger etc), prior to commencement.

SCL is to ensure that all mobile cranes that are hired for use by SCL personnel on site are registered, contain up to date logbooks, and are fitted with adequate safety/protective devices and features (including load cells), prior to their use.

Where a crane company is contracted to undertake specific lifting tasks as part of a designated project, the crane company is to provide a safety plan and documentation that includes, as a minimum, the items contained in Attachment 4.

In the event that information provided by contractors does not contain adequate information, SCL is not to allow crane activities to commence until all required documentation is received.

## Training and Competency

Only competent personnel who have had the necessary training, experience and/or on the job tutoring to safely and correctly use basic chain hoists are to attempt to undertake lifting tasks involving these hoists.

Note: Although not within the scope of this document, operators of personnel carrying hoists such as personnel and materials hoists or cantilever platform hoists do require specific certificates of competency under the various statutory legislative requirements.

All crane operators are to hold the relevant crane licence issued by the relevant statutory authority.

To highlight a particular difference regarding statutory requirements, for bridge or gantry crane operations undertaken in Queensland that involve an operator using a remote control that has three or less powered operations to lift a load that does not exceed 5 tonnes, the operator does not require a certificate of competency. This exclusion however does not mean that the operator does not need to be competent regarding the crane's operation.

All persons involved in the selection, inspection and placement of lifting equipment are to hold a doggers licence issued by the relevant statutory authority, unless details and requirements as specified in Attachment 3 are complied with.

All persons supervising multiple crane lifting operations (ie lift supervisors), are to hold, as a minimum, an intermediate riggers licence.

Note: Refer to [HB#560126 Safety Training Attendance](#), for further information regarding training requirements.

## Review

This Corporate Standard is reviewed every 3 years and on an as needs basis (e.g. following legislative change, new information, relevant incident, etc.).

## Links and References

QLD	Workplace Health & Safety Regulation 2008, Part 3, 17 and Schedule 5
QLD	Plant Code of Practice 2005
QLD	A Guide for Doggers (QLD Government – Department of Employment and Industrial Relations)

# Corporate Standard

## Crane and Hoist Use PTW

HB# 537642

Amd Date 04/01/08

- + + VIC Occupational Health & Safety (Certification of Plant Users & Operators) Regulation 1994, Part 2 & Schedule 1
- + VIC Code of Practice for Plant
- + WA Occupational Health & Safety Regulations 1996, Part 4 and Schedule 4
- + SA Occupational Health, Safety & Welfare Regulations 1995, Part 3 and Schedules 3 & 4
- + NSW Occupational Health & Safety Regulations 2001, Part 5.4 & 9.1
- + ACT Occupational Health and Safety (Certification of Plant Users & Operators) Regulations 2000, Part 4 and Schedule 1, part 2.
- + TAS Workplace Health & Safety Regulations 1998, Part 4
- + NT Workplace Health and Safety Regulations
- + AS 1418 Cranes, hoists and winches – General requirements
- + AS 2550.1 Cranes, hoists and winches – Safe use – General requirements
- + AS 2550.5 Cranes, hoists and winches – Safe use – Mobile cranes
- + AS 1418.17 Cranes (including hoists and winches) – Design and construction of workboxes
- + AS 1418.14 Cranes (including hoists and winches) – Requirements for cranes subject to arduous working conditions.

PTW Procedure

[HB#560126 Safety Training Attendance](#)

[HB#560790 Corporate Standard Electrical Safety](#)

[HB#560726 Corporate Standard Lifting Equipment](#)

[HB#659518 Corporate Standard Barricading and Restricted Access](#)

[PTW Crane and Hoist Use Control Guide](#)

## Attachments

[Attachment 1: Typical Arduous Working Conditions](#)

[Attachment 2: Crane Diagrams](#)

[Attachment 3: Slings and Dogging Information](#)

[Attachment 4: Documentation Required for Mobile Cranes](#)

[Attachment 5: Audit Checklist](#)

[Return To Top](#)

# Corporate Standard

## Crane and Hoist Use PTW

HB# 537642

Amd Date 04/01/08

**Attachment 1: Typical Arduous Working Conditions**

Item	Impact	Consideration
1	Multi-shift operation Multi-driver  Quick maintenance required	Lighting. Ambient temperature. Motor starts, gearbox design, operating temperature; brake heating. L/T wheels and couplings. Accelerations; flexibility of bridge. Cable carriers/mountings. Design for quick exchange of assemblies.
2	High number of adjustments due to plugging, inching	Many starts on drives Bouncing, swinging of load  Swinging of flexible cables
3	High speeds	Wheel/track interface Structural vibration  Driver comfort Positioning accuracy
4	High number of cycles resulting in need for high acceleration and deceleration	Load swing Wheel slip, brakes
5	Crane operation without chaser	Remote control, cabin control, Items 2, 3, 10 and 11.
6	Externally induced vibration	Noise considerations Structural vibration Driver comfort
7	Corrosive/high humidity environment	Structural rust  Electrical/electronic equipment
8	High environmental temperature, radiated heat and thermal shocks	Cabin heat Heat on bridge  Fire risk  Thermal differential in structural components Infra-red control
9	Dust	Cabin environment Ingress into bearings  Ingress into electrical equipment
10	Off vertical lifts	Crab lifting from bridge (mast type) Stability of bridge and crab Side loadings Mast type used for pushing

# Corporate Standard

## Crane and Hoist Use PTW

HB# 537642

Amd Date 04/01/08

11	Impact loads	Driver safety Accidental bumping fixtures by loads Swinging of flexible cables  Collisions with end stops  Structural fatigue design	Anti-collision/slowdown devices. Rope forces equipment stability especially electrical/electronic, operator's sight lines, lights mounting. End stop design, plus above issues. Cable trolleys. Small/light structural members.
12	Severe momentary overloads	Lifted loads caught, e.g. magnets lifting scrap, removing machinery from foundations, frequent turning over of steel structures Uneven lifted load	Increased design factors on structure and mechanisms, chains and ropes.  Extra strain on some hooks and ropes.
13	Movement of runway due to external influences	Vibration Track gauge due to settlement, wind loads, vibration	See Item 6. Runway adjustment, wheel width, floating wheels load factor.

Amd Date 04/01/08

**Attachment 2: Crane Diagrams**  
**Types of Boom Cranes**

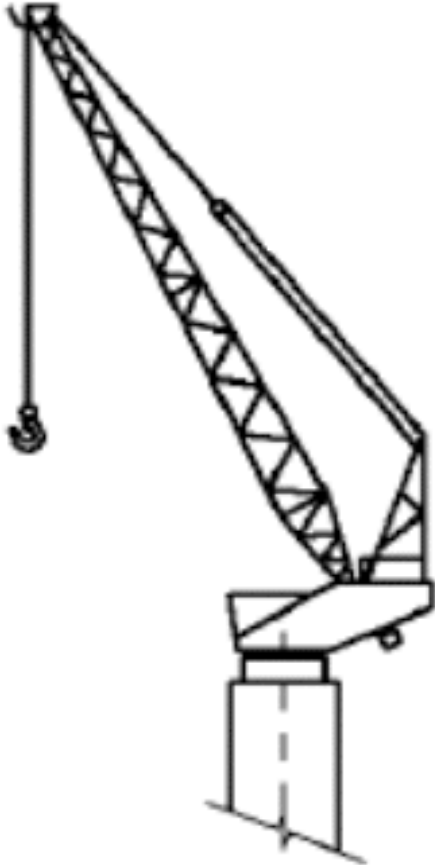

Strut Boom Crane

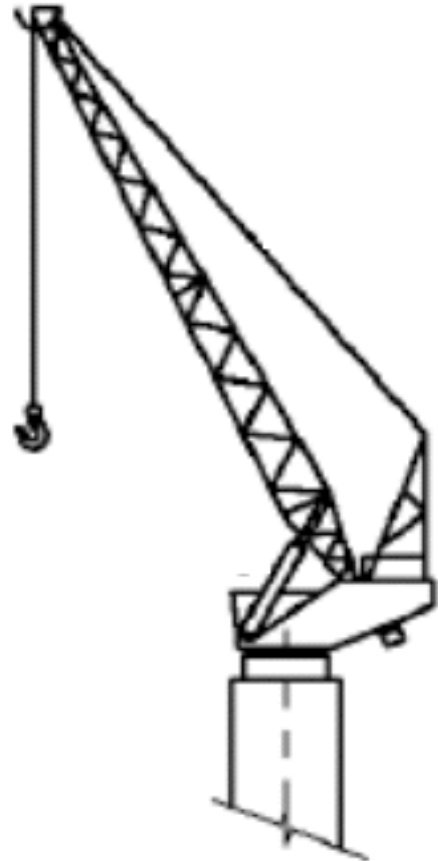

Cantilever Boom Crane

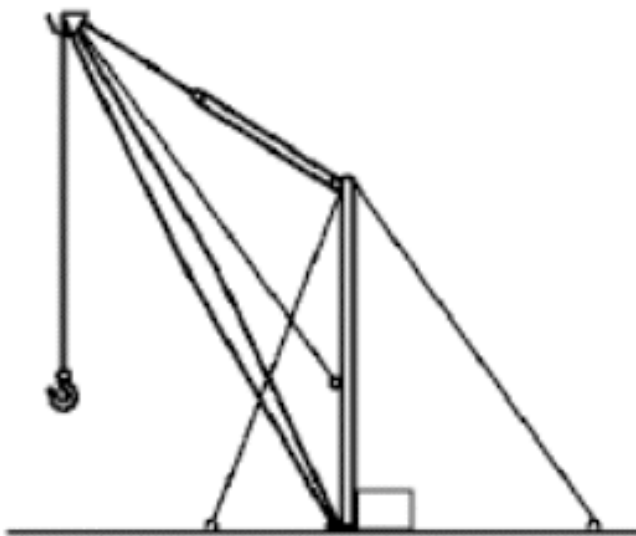

Guy-derrick Crane

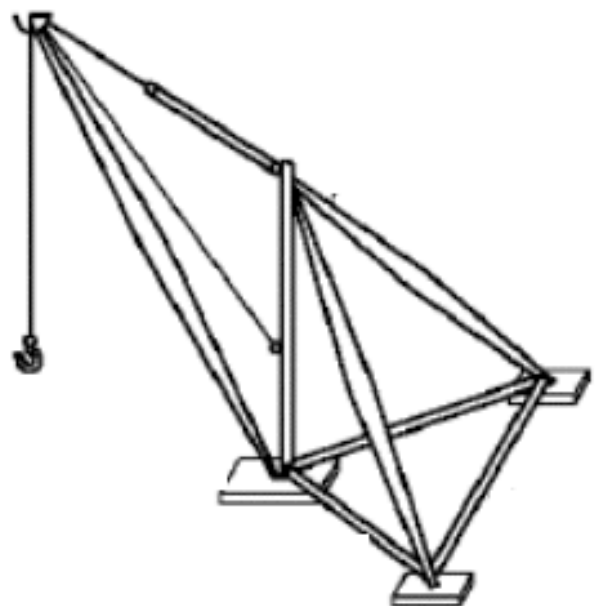

Stiff-leg Derrick Crane

Amd Date 04/01/08

## Types of Bridge and Gantry Cranes

++  
+  
+  
+

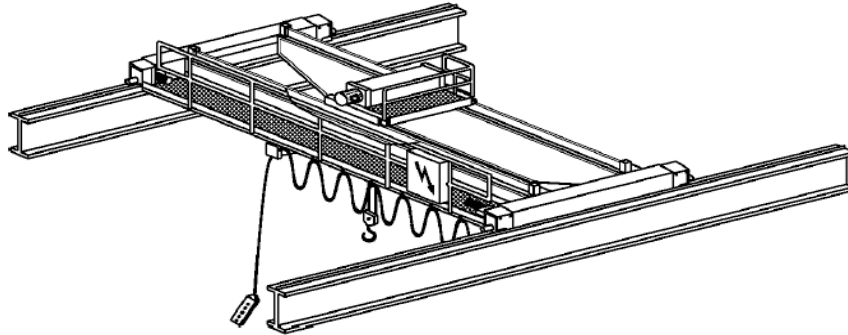

Top-running Double-Girder Bridge Crane with Full-span Walkway

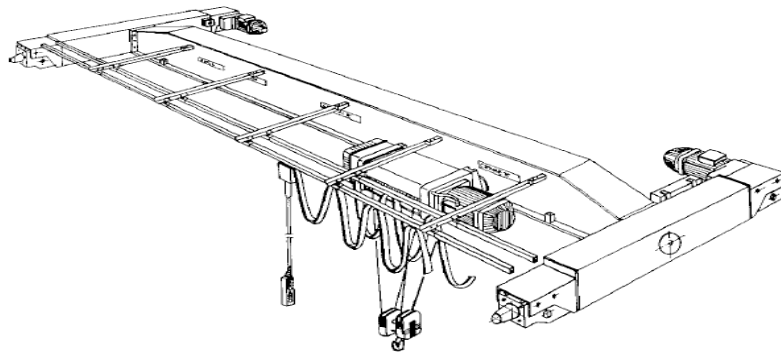

Top-running Single-Girder Bridge Crane

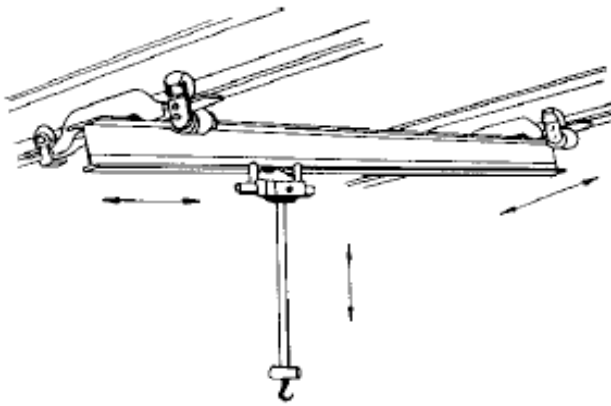

Underslung Bridge Crane

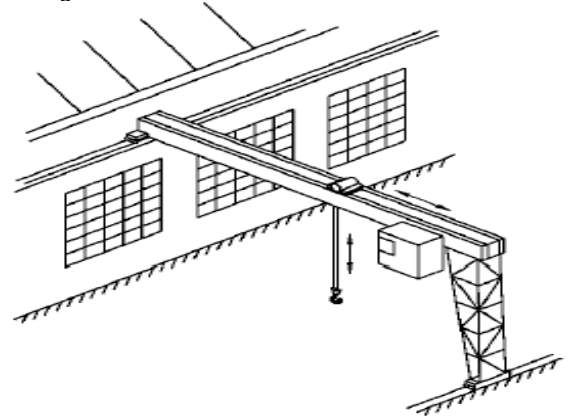

Semi-gantry Crane

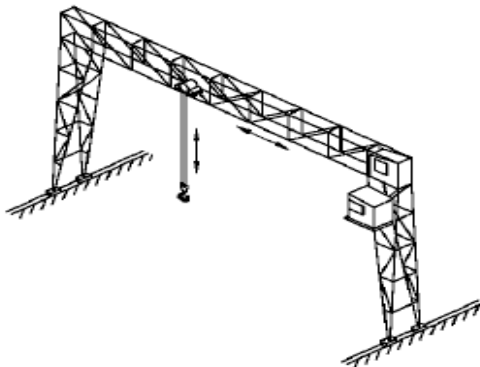

Gantry Crane

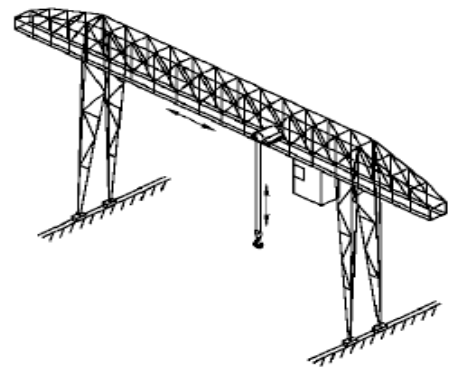

Cantilever Gantry Crane

Amd Date 04/01/08

## Types of Mobile Cranes

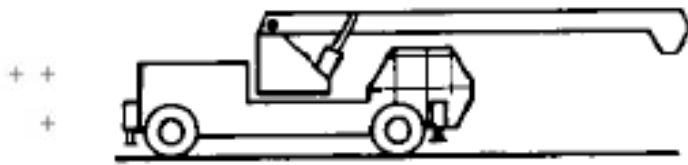

Self-propelled

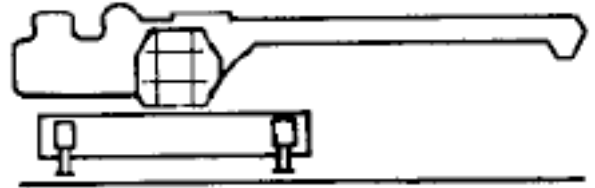

Sub-base-mounted

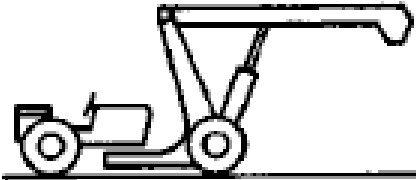

Tractor-based

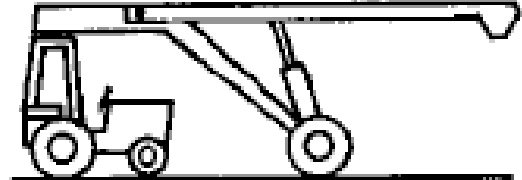

Tractor-connected

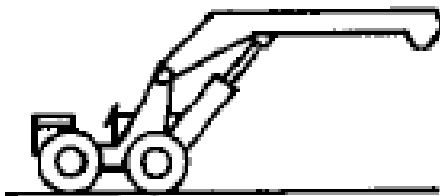

Tractor-mounted

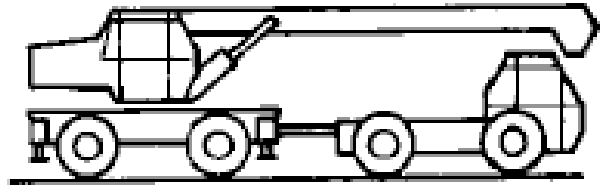

Trailer-mounted

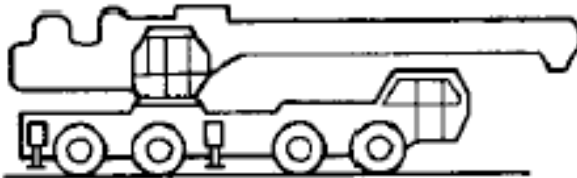

Truck-based

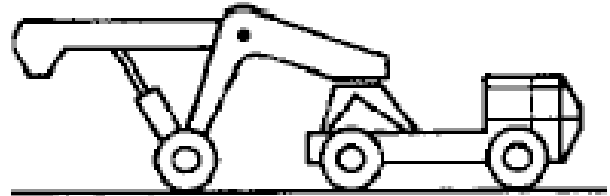

Truck-connected

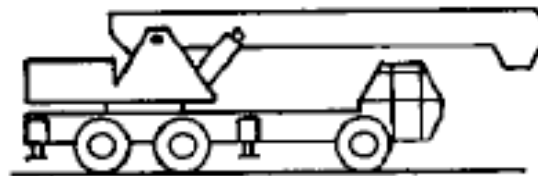

Truck-mounted

## Other Crane Types

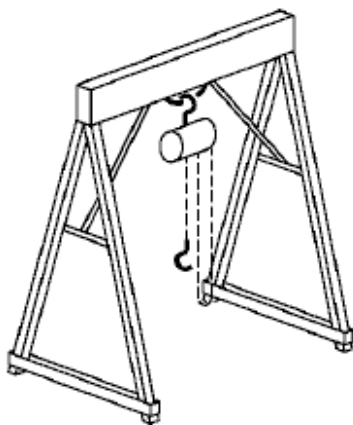

Gallow's Crane

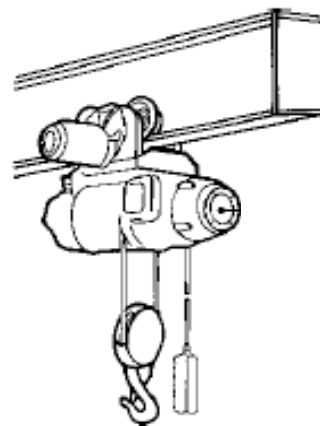

Monorail Crane

Amd Date 04/01/08

**Types of Mobile Crane Masts**

+ +  
+  
+  
+

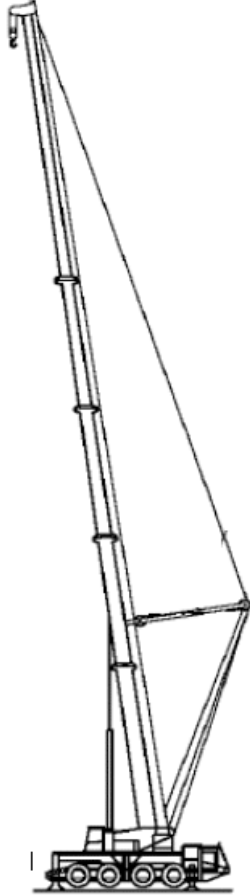

Boom Mast

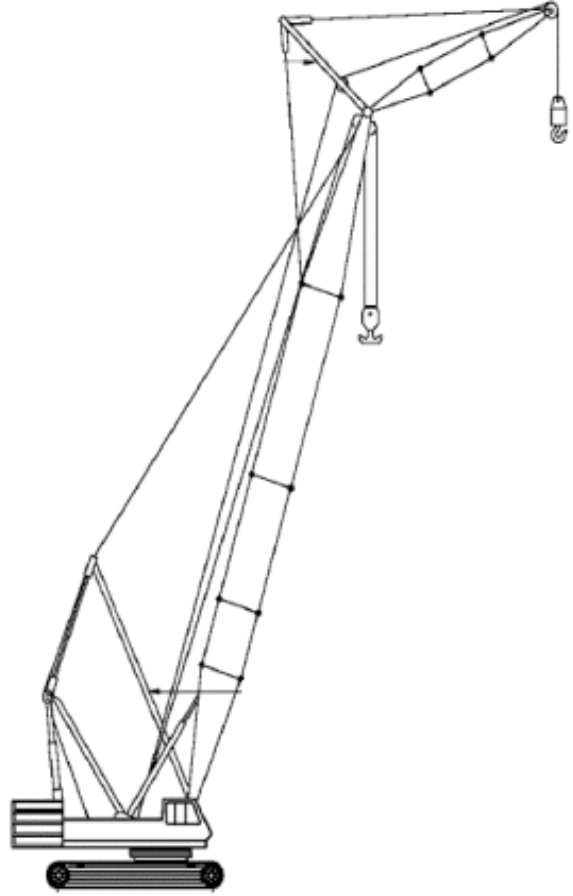

Boom and Fly Jib Masts

## Hoist Suspension Methods

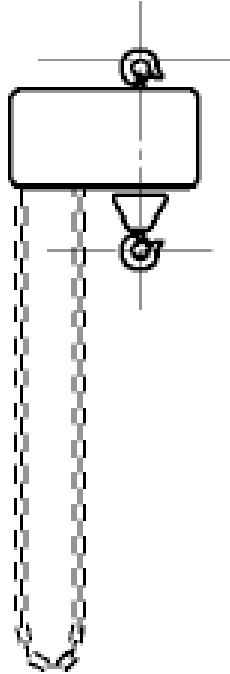

Hoist – Suspension via Hook Method

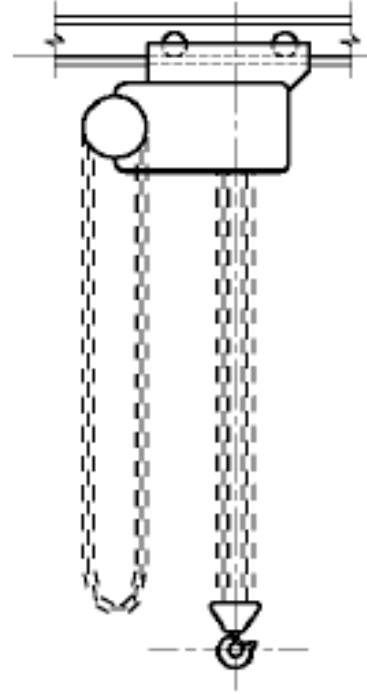

Hoist – Suspension via Trolley Method

### Attachment 3: Slinging and Dogging Information

*Dogger Certificate Information Sheet (95-I-10 October 1995)  
Division of Workplace Health and Safety  
Department of Training and Industrial Relations*

#### Scope

As per this Corporate Standard, dogger is a person who:

- a) uses techniques, including the selection or inspection of lifting gear, to safely sling a load, or
- b) directs a crane or hoist operator in the movement of a load when the load is out of the operator's view.

Such a competent person must possess a Dogger's certificate of competency from one of the various statutory health and safety authorities.

#### Application

Slinging techniques means - the exercising of judgment in relation to the suitability and condition of lifting gear and the method of attaching the sling, including sling accessories, to the load, crane or hoist by consideration of the nature of the load, its mass and its centre of gravity.

For part (a) of the definition - this means a person who has the necessary skills and knowledge to decide the size and application of the lifting gear, shackles, eye bolts, rings, spreader beam, wire, fibre or chain slings etc.) to sling the load.

In application this means that, where a load to be slung varies in size, shape, mass and/or method of attachment to a load, crane or hoist, a dogger would be required to sling the load.

However, in a repetitive work situation where variation does not occur between each application of slinging techniques, (i.e. the size, shape, mass and method of attachment does not change) a dogger would only be required in the first instance to determine the lifting gear and attachment method.

In practical terms this would mean that a non-certified person is able to sling a load, but only in situations where the work method does not vary and the work method has, in the first instance, been established by a dogger.

The non-certified person performing the work would be identified as a trainee. A Trainee can be described (as per varying statutory regulatory requirements) to mean - "a person being trained in a prescribed occupation". Various statutory regulations allow a trainee to perform work in a prescribed occupation.

The trainee can work with a reduced level of supervision provided that the health and safety of the trainee or other persons is not placed at risk and the trainee's competence in performing the task has been assessed.

The obligation to ensure the health and safety of the trainee can be achieved by providing the trainee with instruction and training in the application of the work method for the non-variable lift. To meet this obligation the method of work should be documented and provided to the trainee and the trainee should be instructed via a competency based training method (the trainee must be able to demonstrate the skills and knowledge relative to the documented method of work).

Additionally, part (a) of the definition requires that the lifting gear be inspected at regular intervals. The interval should be determined by the dogger, based on the number of lifting applications and the available information contained in the relevant Australian Standards. The inspection interval should be included in the documented method of work.

Part (b) of the definition is self explanatory and requires that a dogger direct the load whenever the load is out of view of the crane or hoist operator. This means that regardless of the load to be lifted (variable or non variable) a dogger is required whenever the load is out of view of the operator.

### SCL Approach

- + + As described in the *Application* section above, the way in which SCL can achieve compliance with the intent of
- + the non-certified person performing dogging work requirements would be to:
  - ensure that a documented and specific work method statement / risk assessment is developed for the range of specific lifting situations to be undertaken (by certified doggers) as per the above requirements,
  - + ▪ ensure that the method by which these requirements have been communicated (competency based method by certified doggers) has been recorded for each of the personnel who are non certified, including refresher training,
  - + ▪ ensure that only those lifting tasks that have been assessed, documented and for which training has occurred are undertaken by non certified personnel, and
  - ensure that processes are in place to ensure lifting equipment is in safe working condition and that other hazards relating to cranes and the working environment are managed.

**Attachment 4: Documentation Required for Mobile Cranes**Documentation for Mobile Cranes**General**

- Mobile Crane Plant Registration
- List of workers undertaking prescribed work involving the mobile crane (Rigger, Dogger, Crane Operator)

**Pre-Operational and Erection Safe Work Methods / Procedures / Checks**

- Full details of the erection procedure (if applicable) are to be provided prior to work
- All components of the crane are to be inspected by a competent person on the ground prior to erection
- All crane attachments / lifting equipment is to be tested and tagged and in serviceable condition for use on site

**Operational Safe Work Methods / Procedures / Checks**

- Full details of the procedures for operation of the mobile crane are to be provided prior to work. This is to include:
  - Isolation and demarcation of site areas where required;
  - Load Rating Charts and calculations – identifying the various crane configurations / operating radii and the designated rated capacities for each configuration (there are to be displayed permanently in the crane cabin or operating position);
  - Wind considerations;
  - Travelling with loads considerations;
  - Operation in the vicinity of overhead hazards and powerlines.
- Details of daily inspections and a summary of repairs and maintenance are to be supplied in a log book
- Regular inspections are to be undertaken to ensure safe work practices are being correctly undertaken. These include:
  - Pre-operational daily inspections

**Dismantling Safe Work Methods / Procedures / Checks**

- Full details of the procedure for dismantling of the mobile crane (if applicable) is to be supplied with subcontractor / crane operator documentation, separate to those provided for erection of the crane.

**Maintenance Safe Work Methods / Procedures / Checks**

- Competent and authorised personnel only, shall carry out all repairs and maintenance activities
- Where any part of a crane or ancillary equipment becomes worn or unserviceable or may constitute a hazard before the next inspection, then this item shall be replaced / repaired in accordance with the manufacturer's recommendations

Amd Date 04/01/08

**Attachment 5: Audit Checklist**

Item	Status			Action Required	Responsible Person	Completed (Insert Date & Initials)
<b>General Requirements</b>						
Crane Use Control Guides have been completed for appropriate lifting tasks and as a minimum: <ul style="list-style-type: none"> <li>lifts involving multiple cranes (of any type),</li> <li>mobile crane lifts of &gt;50% of the cranes rated capacity (at the final configuration / location required of the lift).</li> </ul>	Yes <input type="checkbox"/>	No <input type="checkbox"/>	NA <input type="checkbox"/>			
Crane workboxes designed in accordance with AS 1418.17 requirements.	Yes <input type="checkbox"/>	No <input type="checkbox"/>	NA <input type="checkbox"/>			
<b>Site Specific Management of Cranes and Hoists</b>						
Inspection and test certificates / records from the manufacturer, supplier or reputable service company are maintained for cranes and hoists.	Yes <input type="checkbox"/>	No <input type="checkbox"/>	NA <input type="checkbox"/>			
Service logbooks within cranes contain details of daily inspections and a summary of repairs and maintenance. Details of crane maintenance, servicing and repairs are maintained in an easily accessible file / register on site.	Yes <input type="checkbox"/>	No <input type="checkbox"/>	NA <input type="checkbox"/>			
Inspection, testing and maintenance of SCL owned lifting equipment undertaken as per HB#560726 Corporate Standard Lifting Equipment.	Yes <input type="checkbox"/>	No <input type="checkbox"/>	NA <input type="checkbox"/>			
<b>Training and Competency of Personnel</b>						
Certification details for crane operators, riggers, and doggers maintained as per corporate training and record keeping requirements.	Yes <input type="checkbox"/>	No <input type="checkbox"/>	NA <input type="checkbox"/>			
High energy, high impact (HEHI) – Complex Crane Use Training delivered to relevant workers.	Yes <input type="checkbox"/>	No <input type="checkbox"/>	NA <input type="checkbox"/>			
Corporate training and record keeping requirements contain detail of HEHI – Complex Crane Use details.	Yes <input type="checkbox"/>	No <input type="checkbox"/>	NA <input type="checkbox"/>			
<b>Contractor Management</b>						
Certification details for contracted crane operators, riggers, and doggers verified and recorded prior to work commencing.	Yes <input type="checkbox"/>	No <input type="checkbox"/>	NA <input type="checkbox"/>			
Mobile cranes hired for SCL operation are registered, contain up to date logbooks and are fitted with adequate safe /	Yes <input type="checkbox"/>	No <input type="checkbox"/>	NA <input type="checkbox"/>			

# Corporate Standard

## Crane and Hoist Use

HB# 537642

Amd Date 04/01/08

protective devices and features.						
Contracted crane companies involved in designated projects / work have provided information as per <i>Attachment 4</i> of this Corporate Standard.	Yes <input type="checkbox"/>	No <input type="checkbox"/>	NA <input type="checkbox"/>			

**Other / Further Details:** \_\_\_\_\_

**Signature of Person Conducting Inspection:** \_\_\_\_\_

**Copies Provided to:** \_\_\_\_\_

(Print First & Last Names)